

ESDxxX-80D

10Gb/s SFP+ DWDM ZR 80km DDM Transceiver

PRODUCT FEATURES

- Support data rate up to 11.3Gb/s
- Support 80 km link distances
- Temperature-Stabilized DWDM EML Transmitter and APD Receiver
- Duplex LC connector
- Low power consumption:
Commercial:<1.5W
Industrial: <1.8W
- Positive power supply lines: 3.3 V
- Operating case temperature range:
Commercial:0 to 70 deg C
Industrial: -40 to 85 deg C
- RoHS 6 compliant
- Compliant with SFF-8431 / SFF-8472

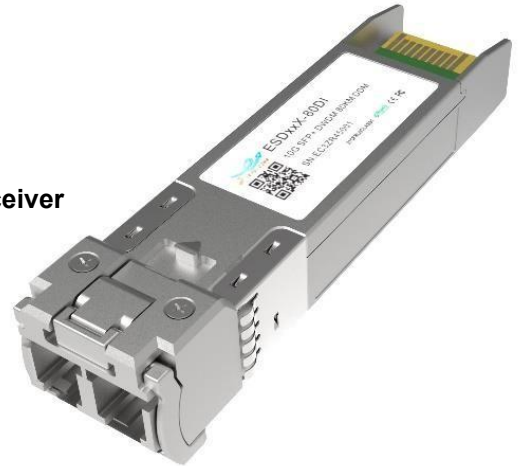

APPLICATIONS

- DWDM 10Gb/s Ethernet

Description

The ESDxxX-80D(I) is a hot pluggable 3.3V Small-Form-Factor pluggable tunable SFP+ transceiver module for use in the up to 11.3Gb/s single mode high-speed communications equipment . Digital diagnostic functions are available via 2-wire serial interface, as specified in SFF-8431.

Ordering information

Part No.	Data Rate(optical)	Laser	Fiber Type	Distance	Optical Interface	Temp	DDMI
ESDxxX-80D	10.3125Gbps	EML	SMF	80km	LC	0~70°C	Y
ESDxxX-80DI	10.3125Gbps	EML	SMF	80km	LC	-40~85°C	Y

I.Wavelength Guide Table

Channel	Wavelength (nm)	Frequency (THZ)	Channel	Wavelength (nm)	Frequency (THZ)
C12	1567.95	191.20	C42	1543.73	194.20
C13	1567.13	191.30	C43	1542.94	194.30
C14	1566.31	191.40	C44	1542.14	194.40
C15	1565.50	191.50	C45	1541.35	194.50
C16	1564.68	191.60	C46	1540.56	194.60
C17	1563.86	191.70	C47	1539.77	194.70
C18	1563.05	191.80	C48	1538.98	194.80
C19	1562.23	191.90	C49	1538.19	194.90
C20	1561.42	192.00	C50	1537.40	195.00
C21	1560.61	192.10	C51	1536.61	195.10
C22	1559.79	192.20	C52	1535.82	195.20
C23	1558.98	192.30	C53	1535.04	195.30
C24	1558.17	192.40	C54	1534.25	195.40
C25	1557.36	192.50	C55	1533.47	195.50
C26	1556.55	192.60	C56	1532.68	195.60
C27	1555.75	192.70	C57	1531.90	195.70
C28	1554.94	192.80	C58	1531.12	195.80
C29	1554.13	192.90	C59	1530.33	195.90
C30	1553.33	193.00	C60	1529.55	196.00
C31	1552.52	193.10	C61	1528.77	196.10
C32	1551.72	193.20	C62	1527.99	196.20
C33	1550.92	193.30	C63	1527.22	196.30
C34	1550.12	193.40	C64	1526.44	196.40

C35	1549.32	193.50	C65	1525.66	196.50
C36	1548.51	193.60	C66	1524.89	196.60
C37	1547.72	193.70	C67	1524.11	196.70
C38	1546.92	193.80	C68	1523.34	196.80
C39	1546.12	193.90	C69	1522.56	196.90
C40	1545.32	194.00	C70	1521.79	197.00
C41	1544.53	194.10			

II. Absolute Maximum Ratings

Parameter	Symbol	Min	Typ	Max	Units
Storage Temperature	T _{stg}	-40	-	85	°C
Relative Humidity - Storage	RH _o	5	-	95	%
Relative Humidity - Operating	RH _s	5	-	85	%
Power Supply	V _{cc}	-0.5	-	3.6	V

III. Recommended Operating Conditions

Parameter	Symbol	Min	Typ	Max	Units	Notes
Case Operating Temperature		-40	25	85	°C	Temperature Range = I
Case Operating Temperature		0	25	70	°C	Temperature Range = C
DC Supply Voltage	V _{cc}	3.13	-	3.47	V	

IV. Electrical Characteristics

High-Speed Signal: Compliant to CEI-11G-SR

Low-Speed Signal: Compliant to SFF-8419

Parameter	Symbol	Min.	Typical	Max.	Unit	Notes
Transmitter (Module Input)						
Differential Input Resistance	R _{Rdin}	80	100	120	Ω	
Input Differential Voltage	R _{Vdiff}	110	-	1050	mVpp	
Tx_Disable	Normal Operation	V _{IL}	-0.3	-	0.8	V
	Laser Disable	V _{IH}	2.0	-	V _{cc} +0.3	V
Receiver (Module Output)						
Differential Resistance	T _{Rd}	80	100	120	Ohm	

Optical Communications Products Alliance

Output Differential Voltage		T_V _{diff}	360	-	770	mVpp	
Differential Termination Resistance Mismatch		T_R _{dm}	-	-	5	%	
Rx los	Normal Operation	V _{OL}	-0.3	-	0.4	V	
	Loss Signal	V _{OH}	2		V _{CCHOST}	V	

V. Optical Characteristics

Parameter	Symbol	Min.	Typical	Max.	Unit	Notes
Transmitter						
Average Output Power	POUT	0		4	dBm	
Average Output Power(Laser Off)	POFF			-30	dBm	
Wavelength	λ	$\lambda_c-0.1$	λ_c	$\lambda_c+0.1$	nm	
Spectrum Bandwidth @ -20dB	$\Delta\lambda$			1	nm	
Side mode suppression ratio(SMSR)	SMSR	30			dB	
Extinction ratio	ER	8.2			dB	
Transmitter waveform and dispersion penalty (TWDP)				4.7	dB	
RIN _{20OMA}	RIN			-128	dB/Hz	
Optical return loss tolerance	ORLT	20			dB	
Receiver						
Wavelength	λ	1260		1620	nm	
Received Sensitivity	P _{IN}			-23	dBm	BER<1x10 ⁻¹²
Optical Power Overload	P _{IN} (SAT)	-6			dBm	
Damage threshold			-5		dBm	
Receiver Reflectance	RFL			-12	dB	
Rx_LOS of Signal Assert	P _A	-35			dBm	
Rx_LOS of Signal De-assert	P _D			-25	dBm	
Rx_LOS of Signal Hysteresis	PHy	0.5		5	dB	
Optical Return Loss Tolerance	ORLT	20			dB	

VI. Digital Diagnostic Monitor Accuracy

The following characteristics are defined over recommended operating condition

Parameter	Range	Accuracy	Unit	Calibration
Temperature	-40 to 85	±3	°C	Internal
Voltage	0 to V _{cc}	±3%	V	Internal
Tx Bias Current	0 to 100	±10%	mA	Internal
Tx Output Power	-1 to 4	±3	dB	Internal
Rx Input Power	-24 to -6	±3	dB	Internal

VII. Pin Diagram

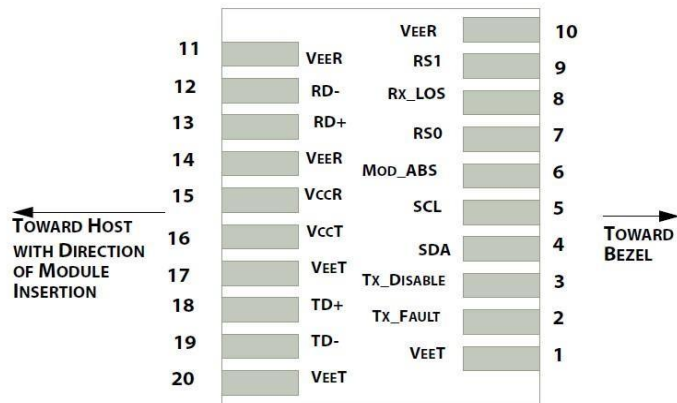

VIII. Pin Descriptions

PIN #	Name	Function	Notes
1	VeeT	Module transmitter ground	1
2	Tx Fault	Module transmitter fault	2
3	Tx Disable	Transmitter Disable; Turns off transmitter laser output	3
4	SDL	2 wire serial interface data input/output (SDA)	4
5	SCL	2 wire serial interface clock input (SCL)	4
6	MOD-ABS	Module Absent, connect to VeeR or VeeT in the module	4
7	RS0	Rate select0, optionally control SFP+ receiver. When high, input data rate >4.5Gb/s; when low, input data rate <=4.5Gb/s	5
8	LOS	Receiver Loss of Signal Indication	6
9	RS1	Rate select0, optionally control SFP+ transmitter. When high, input data rate >4.5Gb/s; when low, input data rate <=4.5Gb/s	1
10	VeeR	Module receiver ground	1
11	VeeR	Module receiver ground	1
12	RD-	Receiver inverted data output	
13	RD+	Receiver non-inverted data output	
14	VeeR	Module receiver ground	1
15	VccR	Module receiver 3.3V supply	
16	VccT	Module transmitter 3.3V supply	
17	VeeT	Module transmitter ground	1
18	TD+	Transmitter inverted data output	
19	TD-	Transmitter non-inverted data output	
20	VeeT	Module transmitter ground	1

Notes:

- Circuit ground is internally isolated from chassis ground
- Tx FAULT is an open collector/drain output, which should be pulled up with a 4.7k – 10k Ohms resistor on the host board if intended for use. Pull up voltage should be between 2.0V to Vcc + 0.3V. A high output indicates a transmitter fault caused by either the TX bias current or the TX output power exceeding the preset alarm thresholds. A low output indicates normal operation. In the low state, the output is pulled to <0.8V.

Optical Communications Products Alliance

3. Laser output disabled on Tx DIS >2.0V or open, enabled on Tx DIS <0.8V.
4. Should be pulled up with 4.7kΩ- 10kΩ host board to a voltage between 2.0V and 3.6V. MOD_ABS pulls line low to indicate module is plugged in.
5. Internally pulled down per SFF-8431 Rev 4.1.
6. LOS is open collector output. It should be pulled up with 4.7kΩ – 10kΩ on host board to a voltage between 2.0V and 3.6V. Logic 0 indicates normal operation; logic 1 indicates loss of signal.

IX. Recommend Circuit Schematic

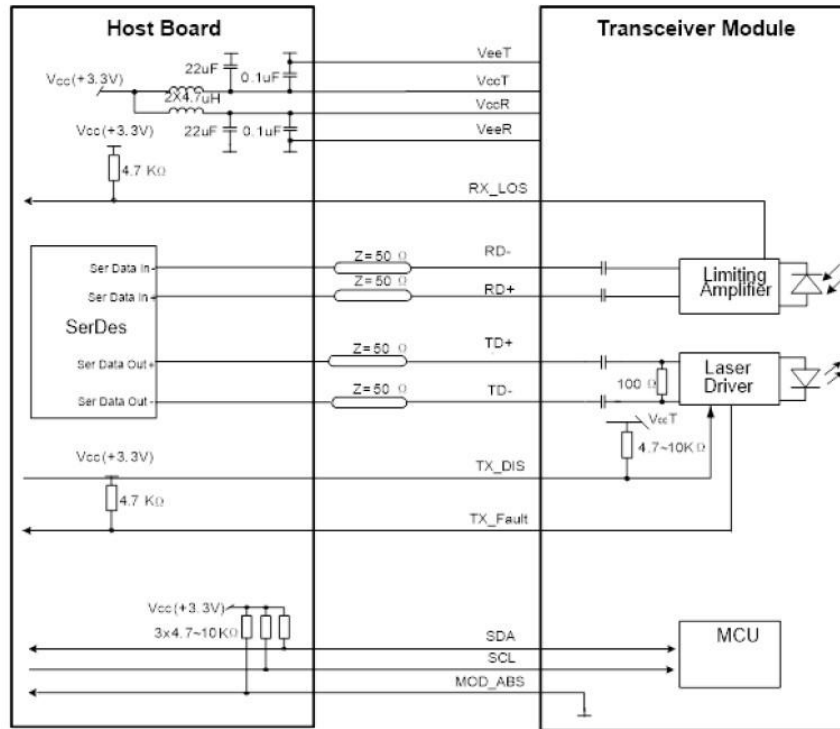

X.Mechanical Specifications(Unit: mm)

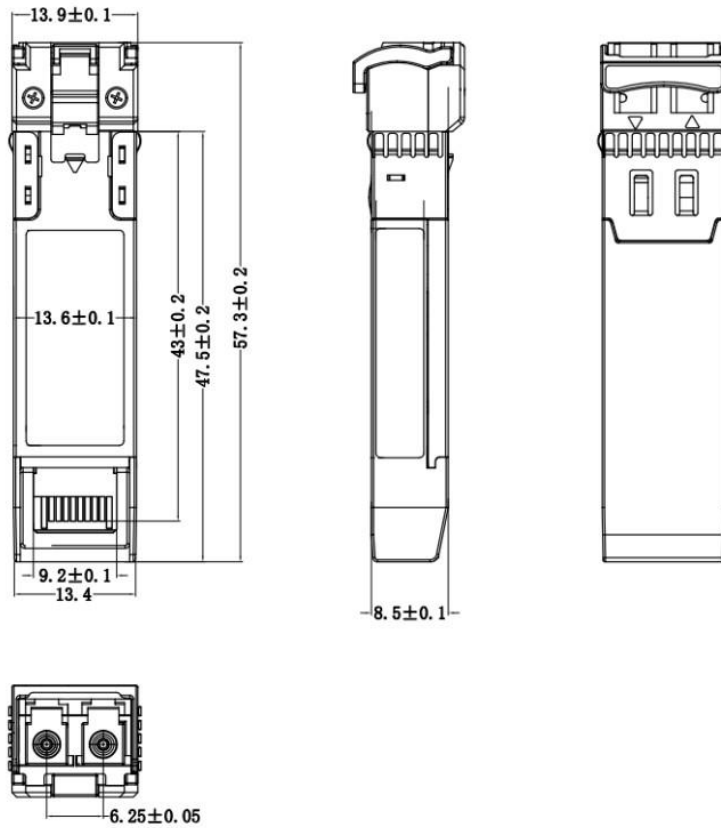

Contact:

Company: ETU-Link Technology Co., LTD

Address: Right side of 3rd floor, No. 102 building, Longguan expressway, Dalang street, Longhua District, Shenzhen city, Guangdong Province, China 518109

Tel: +86-755 2328 4603

Addresses and phone number also have been listed at www.etulinktechnology.com.

Please e-mail us at sales@etulinktechnology.com or call us for assistance.