

# EB29(92)Y-80D-B

## 100G QSFP28 ZR4 BIDI Optical Transceiver

### PRODUCT FEATURES

- Support line rates from 103.125 Gb/s;
- Lane bit rate 25.78 Gb/s 100GE
- Up to 80km transmission with KR4-FEC.
- LAN WDM EML laser and PIN receiver with SOA;
- Support Multi-Pin function with IntL/RxLOSL and LPMODE/TxDIS;
- High speed I/O electrical interface (CAUI-4);
- I2C interface with integrated Digital Diagnostic monitoring;
- QSFP28 MSA package with simplex LC connector;
- Single +3.3V power supply

Power dissipation

Commercial: < 5.5W

- Complies with EU Directive 2015/863/EU

### APPLICATIONS

- 100GBASE-ZR4 Ethernet
- 100G Datacom & Telecom connections

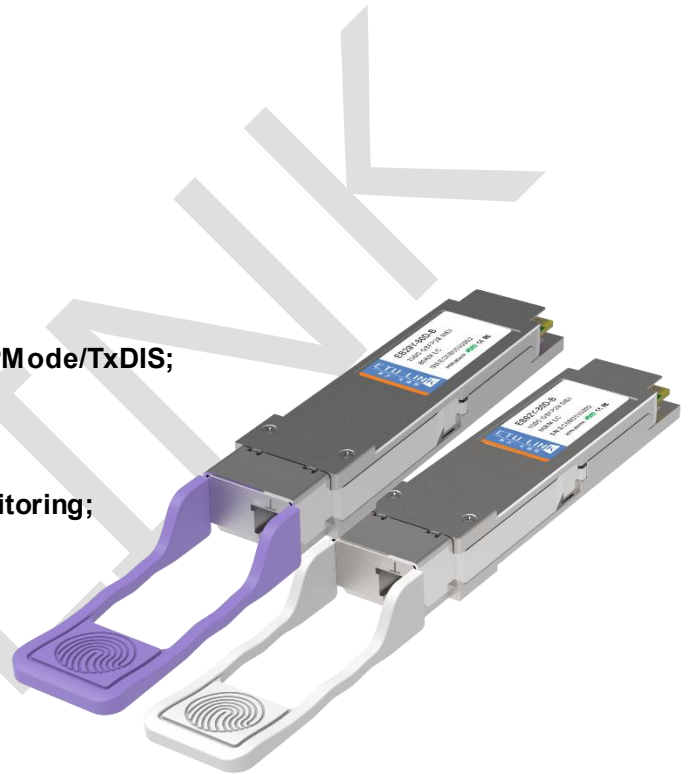

## Description

ETU-LINK's EB29(92)Y-80D-B is designed for 80km optical communication applications. Optical transceiver integrates the transmit and receive path onto one module. On the transmit side, four lanes of serial data streams are recovered, retimed, and passed on to four laser drivers, which control four electric-absorption modulated lasers (Lan-WDM) with 1273,1278,1282,1286, 1296, 1300, 1305, and 1309 nm center wavelengths. The optical signals are then multiplexed into a single-mode fiber through an industry-standard LC connector. On the receive side, four lanes of optical data streams are optically DE multiplexed by an integrated optical DE multiplexer. After the optical signal is amplified by SOA, DEMUX separates four channels which are recovered by PIN photodetector and cross-impedance amplifier, retimed and passed on to an output driver. This module features a hot-pluggable electrical interface, low power consumption, and 2-wire serial interface.

## Module Block Diagram

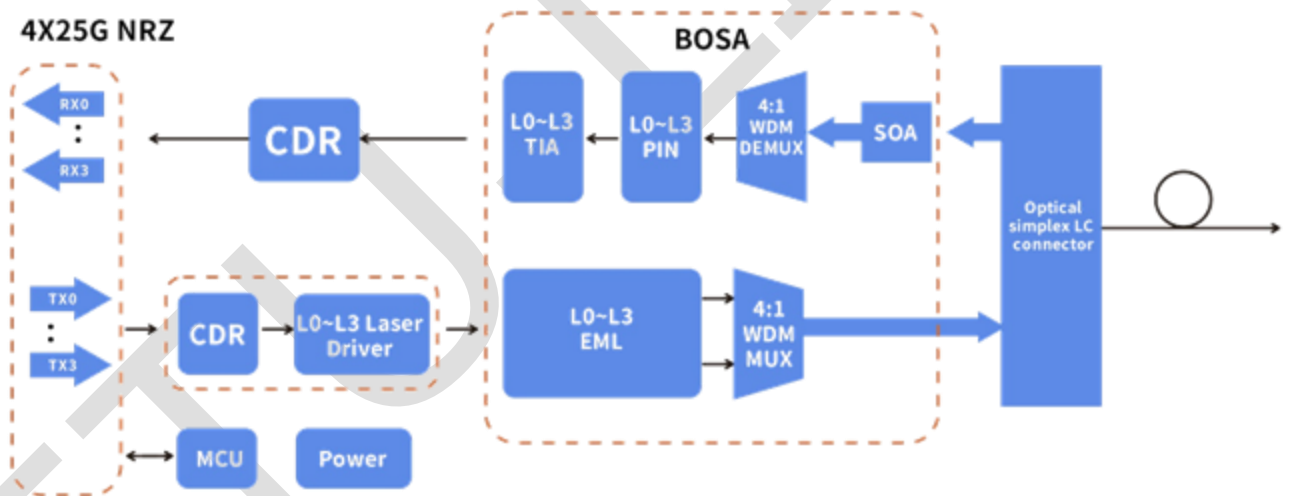

## Ordering information

Part No.	Data Rate (Gbps)	Laser	Fiber Type	Transmission Distance (km)	Optical Interface	Temp (°C)	DDMI
EB29Y-80D-B	103.125	LWDM	SMF	80	LC	0~70	Y
EB92Y-80D-B	103.125	LWDM	SMF	80	LC	0~70	Y

## Model wavelength specification

Part No.	TX Center Wavelength	RX Center Wavelength
EB29Y-80D-B	Lane0 1273.55	Lane0 1295.56
	Lane1 1277.89	Lane1 1300.05
	Lane2 1282.26	Lane2 1304.58
	Lane3 1286.66	Lane3 1309.14
EB92Y-80D-B	Lane0 1295.56	Lane0 1273.55
	Lane1 1300.05	Lane1 1277.89
	Lane2 1304.58	Lane2 1282.26
	Lane3 1309.14	Lane3 1286.66

## Recommend Operating Conditions

Parameter	Symbol	Min	Typ	Max	Unit	Notes
Operating Case Temperature	Top	0		+70	°C	
Power Supply Voltage	VCC	3.14	3.3	3.47	V	
Maximum Power Dissipation	P <sub>D</sub>			5.5	W	
Lane Bit Rate			25.78125		Gb/s	
Transmission Distance	TD			80	km	
Coupled fiber	Single mode fiber					1

Notes:

- Optical fiber use 9/125um SMF.

## Absolute Maximum Ratings

It has to be noted that the operation in excess of any individual absolute maximum ratings might cause permanent damage to this module.

Parameter	Symbol	Min	Max	Unit	Notes
Storage Temperature	TS	-40	85	degC	
Operating Case Temperature	TOP	0	70	degC	
Power Supply Voltage	VCC	-0.5	3.6	V	
Damage Threshold, each Lane	THd	5.5		dBm	
RelativeHumidity (non-condensation)	RH	0 to 85% non-condensing		%	

The following characteristics are defined over the Recommended Operating Environment unless otherwise specified.

## Electrical Characteristics

The following electrical characteristics are defined over the Recommended Operating Environment unless otherwise specified.

Parameter	Test Point	Min	Typ	Max	Unit	Notes
<b>Transmitter (Module Input)</b>						

## Optical Communications Products Alliance

Data Rate, each lane			25.78125		Gbps	
Differential Voltage pk-pk	Vpp			900	Mv	1
Common Mode Voltage	Vcm	-350		2850	Mv	
Transition time	Trise/Tfall	10			ps	2
<b>Receiver (Module Output)</b>						
Data Rate, each lane				25.78125		
Common Mode Noise, RMS	Vrms			17.5	Mv	
Differential output voltage swing	Vout, pp			900	Mv	
Eye width	EW15	0.57			UI	
Eye height	EH15	228			mV	
Differential Termination Resistance Mismatch				10	%	1
Transition time	Trise/Tfall	12			ps	
Data Rate, each lane			25.78125		Gbps	
Common Mode Noise, RMS	Vrms			17.5	Mv	

Notes:

1. At 1 MHz.
2. 20%~80%.

## Optical Characteristics

Parameter	Symbol	Min	Typ	Max	Unit	Note
<b>Transmitter</b>						
Signaling Speed per Lane			25.78125		Gbps	
Center Wavelength Lane 0	$\lambda_0$	1272.55	1273.55	1274.54	nm	EB29Y-80D-B
Center Wavelength Lane 1	$\lambda_1$	1276.89	1277.89	1278.89	nm	
Center Wavelength Lane 2	$\lambda_2$	1281.25	1282.26	1283.27	nm	
Center Wavelength Lane 3	$\lambda_3$	1285.65	1286.66	1287.68	nm	
Center Wavelength Lane 4	$\lambda_4$	1294.53	1295.56	1296.59	nm	EB92Y-80D-B
Center Wavelength Lane 5	$\lambda_5$	1299.02	1300.05	1301.09	nm	
Center Wavelength Lane 6	$\lambda_6$	1303.54	1304.58	1305.63	nm	
Center Wavelength Lane 7	$\lambda_7$	1308.09	1309.14	1310.19	nm	
Total Launch Power, 100GE	P <sub>T</sub>	8		12.5	dBm	1
Average Launch Power per Lane,	P <sub>avg</sub>	2		6.5	dBm	1
OMA, each Lane	P <sub>OMA</sub>	2		6.5	dBm	1
Difference in launch power between any two lanes(Average and OMA) between any Two Lanes	P <sub>tx,diff</sub>			3	dB	

(OMA)						
Average Output Power (Laser Turn off)	$P_{off}$			-30	dBm	
Side Mode Suppression Ratio	SMSR	30			dB	
Extinction Ratio, 100GE	ER	6			dB	
RIN20OMA	RIN			-130	dB/Hz	
Optical Return Loss Tolerance	TOL			20	dB	
Transmitter Reflectance	$R_T$			-12	dB	
Optical Eye Mask	{0.25,0.4, 0.45, 0.25, 0.28, 0.4}				%	2
<b>Receiver</b>						
Signaling rate, each lane			25.78125		Gbps	
Center Wavelength Lane 0	$\lambda_0$	1294.53	1295.56	1296.59	nm	EB29Y-80D-B
Center Wavelength Lane 1	$\lambda_1$	1299.02	1300.05	1301.09	nm	
Center Wavelength Lane 2	$\lambda_2$	1303.54	1304.58	1305.63	nm	
Center Wavelength Lane 3	$\lambda_3$	1308.09	1309.14	1310.19	nm	
Center Wavelength Lane 4	$\lambda_4$	1272.55	1273.55	1274.54	nm	EB92Y-80D-B
Center Wavelength Lane 5	$\lambda_5$	1276.89	1277.89	1278.89	nm	
Center Wavelength Lane 6	$\lambda_6$	1281.25	1282.26	1283.27	nm	
Center Wavelength Lane 7	$\lambda_7$	1285.65	1286.66	1287.68	nm	
Damage threshold , each lane	$P_{damage}$	5.5			dBm	
Receiver sensitivity Average, each lane	SEN			-26	dBm	3
Los Assert	LosA	-40			dBm	
Los De-assert	LosDA			-28	dBm	

**Notes:**

1. The optical power is launched into SMF.
2. Measured with a PRBS  $2^{31}-1$  test pattern @25.78125, Hit ratio $\leq 5E-5$ .
3. Measured with a PRBS  $2^{31}-1$  test pattern @25.78125 Gb/s, BER $\leq 5E-5$ .

## Digital Diagnostic Monitoring Specifications

Parameter	Unit	Specification
Temperature Monitor absolute error	°C	$\pm 3.0$
Supply Voltage Monitor absolute error	%	$\pm 5^\circ\text{C}$
I_bias Monitor absolute error	%	$\pm 10$
Received Power (Rx) Monitor absolute error	dB	$\pm 3.0$
Transmit Power (Tx) Monitor absolute error	dB	$\pm 3.0$

Pin Assignment and Description

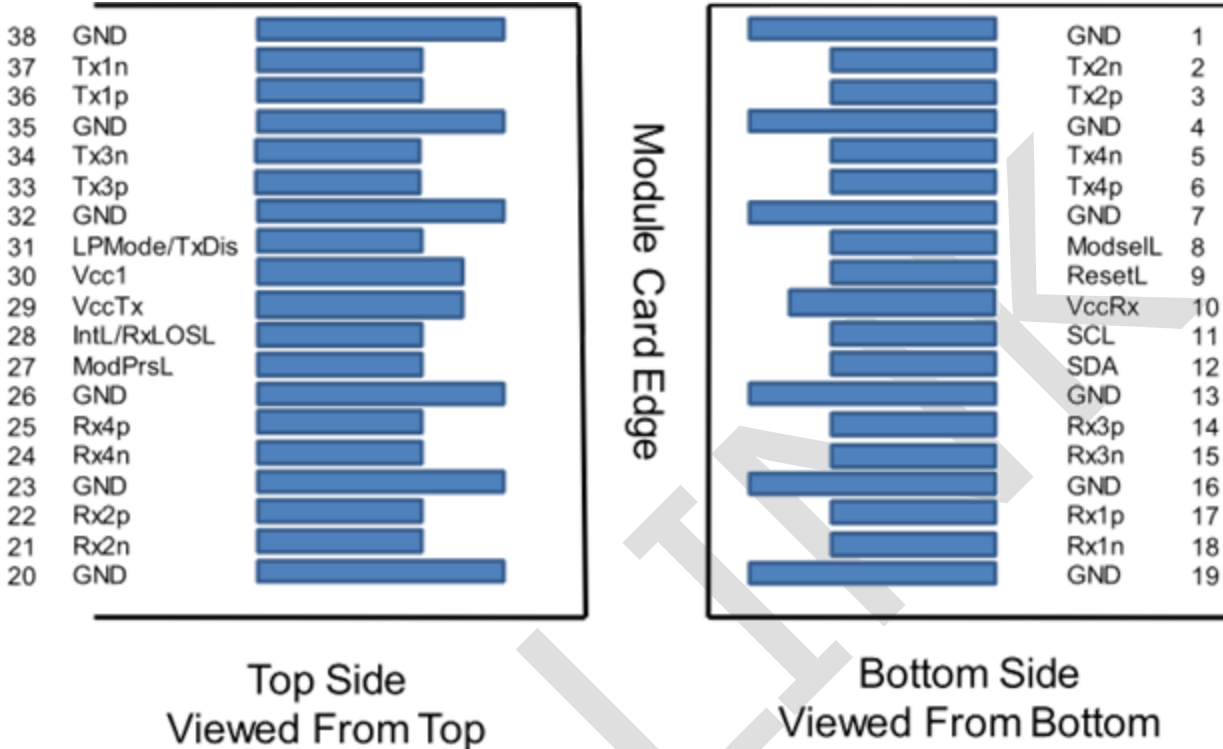

PIN	Logic	Symbol	Description	Plug Seq.	Notes
1		GND	Ground	1	1
2	CML-I	Tx2n	Transmitter Inverted Data Input	3	
3	CML-I	Tx2p	Transmitter Non-Inverted Data output	3	
4		GND	Ground	1	1
5	CML-I	Tx4n	Transmitter Inverted Data Input	3	
6	CML-I	Tx4p	Transmitter Non-Inverted Data output	3	
7		GND	Ground	1	1
8	LVTLL-I	ModSelL	Module Select	3	
9	LVTLL-I	ResetL	Module Reset	3	
10		VccRx	+ 3.3V Power Supply Receiver	2	2
11	LVC MOS-I/O	SCL	2-Wire Serial Interface Clock	3	
12	LVC MOS-I/O	SDA	2-Wire Serial Interface Data	3	
13		GND	Ground	1	
14	CML-O	Rx3p	Receiver Non-Inverted Data Output	3	

15	CML-O	Rx3n	Receiver Inverted Data Output	3	
16		GND	Ground	1	1
17	CML-O	Rx1p	Receiver Non-Inverted Data Output	3	
18	CML-O	Rx1n	Receiver Inverted Data Output	3	
19		GND	Ground	1	1
20		GND	Ground	1	1
21	CML-O	Rx2n	Receiver Inverted Data Output	3	
22	CML-O	Rx2p	Receiver Non-Inverted Data Output	3	
23		GND	Ground	1	1
24	CML-O	Rx4n	Receiver Inverted Data Output	3	1
25	CML-O	Rx4p	Receiver Non-Inverted Data Output	3	
26		GND	Ground	1	1
27	LVTTTL-O	ModPrsL	Module Present	3	
28	LVTTTL-O	IntL/Rx_LOS	Interrupt/Rx_LOS	3	
29		VccTx	+3.3 V Power Supply transmitter	2	2
30		Vcc1	+3.3 V Power Supply	2	2
31	LVTTTL-I	LPMoDe/TxDIS	Low Power Mode/Tx_Disable	3	
32		GND	Ground	1	1
33	CML-I	Tx3p	Transmitter Non-Inverted Data Input	3	
34	CML-I	Tx3n	Transmitter Inverted Data Output	3	
35		GND	Ground	1	1
36	CML-I	Tx1p	Transmitter Non-Inverted Data Input	3	
37	CML-I	Tx1n	Transmitter Inverted Data Output	3	
38		GND	Ground	1	1

## Notes:

1. GND is the symbol for signal and supply (power) common for the QSFP28 module. All are common within the QSFP28 module and all module voltages are referenced to this potential unless otherwise noted. Connect these directly to the host board signal-common ground plane.
2. Vcc Rx, Vcc1 and Vcc Tx are the receiver and transmitter power supplies and shall be applied concurrently. Requirements defined for the host side of the Host Edge Card Connector are listed in MSA. The connector pins are each rated for a maximum current of 1000 Ma.

### Recommended Interface Circuit

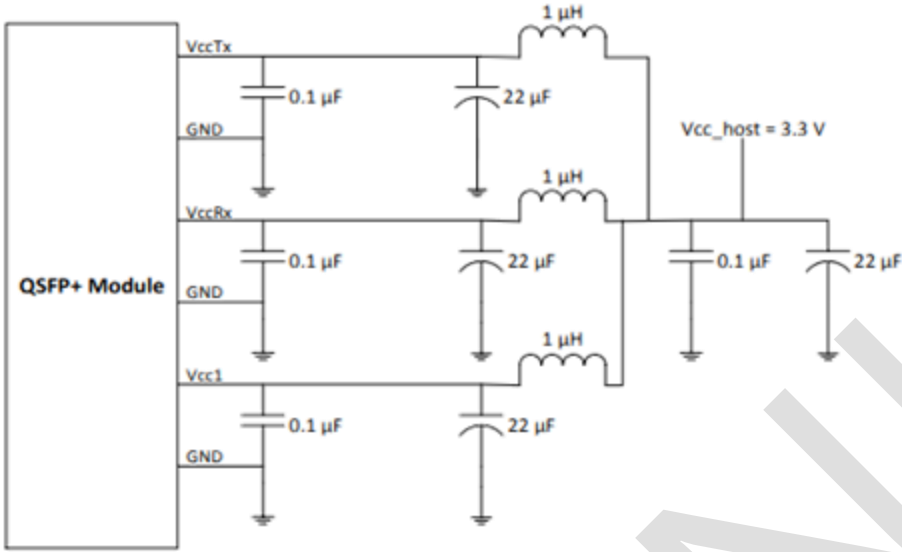
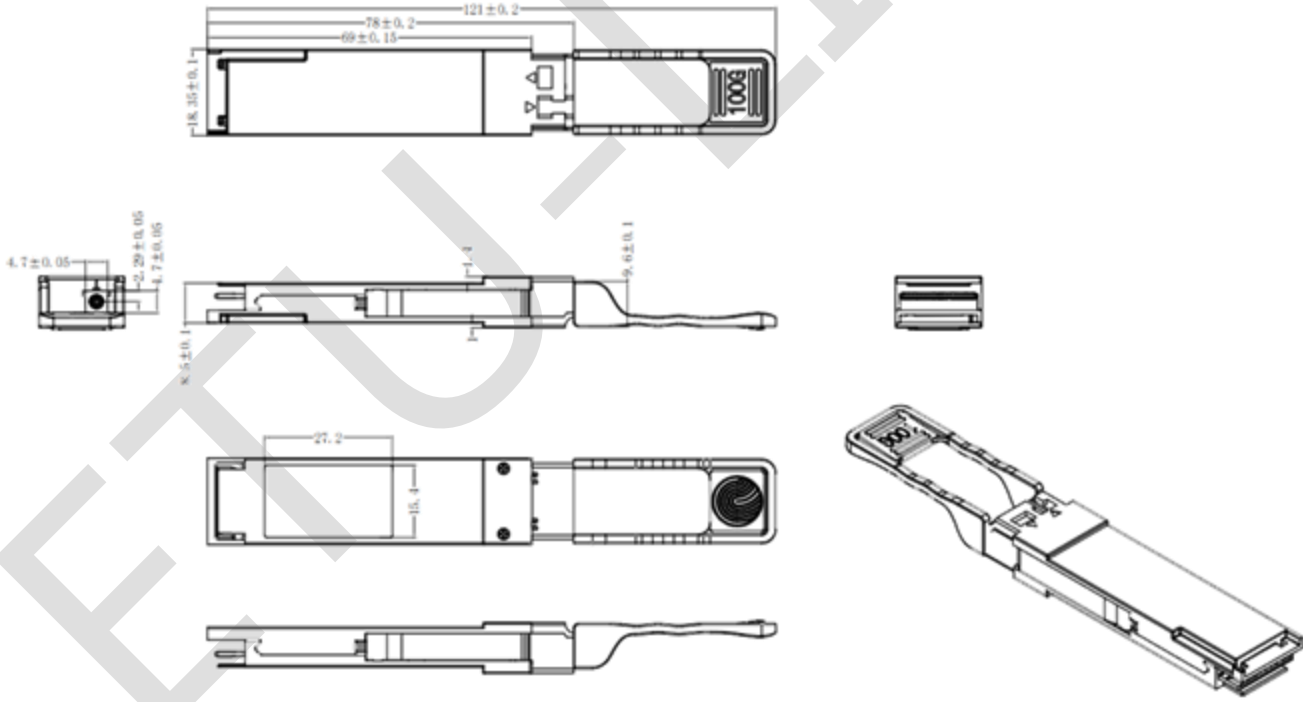

FIGURE 5-4 RECOMMENDED HOST BOARD POWER SUPPLY FILTERING

### Mechanical Dimensions



### Revision History

Version No.	Date	Description
1.0	Aug,17, 2024	Preliminary datasheet
1.1	Apr,01, 2026	Update the appearance structure diagram.

Company: ETU-Link Technology Co., LTD

Address: Right side of 3rd floor, No. 102 building, Longguan expressway, Dalang street, Longhua District, Shenzhen city, GuangDong Province, China 518109

Tel: +86-755 2328 4603

Addresses and phone number also have been listed at [www.etulinktechnology.com](http://www.etulinktechnology.com).

Please e-mail us at [sales@etulinktechnology.com](mailto:sales@etulinktechnology.com) or call us for assistance.

ETU-LINK