

EQP89Y-01D-SW4

100G Compatible Rate QSFP28 SWDM4 Optical Transceiver

PRODUCT FEATURES

- **Compliant with QSFP28 MSA;**
- **Compliant with SWDM MSA;**
- **Compliant with IEEE802.3bm CAUI-4**
- **Hot-pluggable QSFP28 form factor**
- **4x25Gb/s 850/880/910/940nm VCSEL-based transmitter**
- **Supports 100G Dual-Rate operation**
- **Power dissipation<3.5W**
- **Maximum link length of 150m on OM5 multimode Fiber**
- **Case temperature range of 0°C to 70°C**
- **Duplex LC receptacles**
- **CAUI-4 electrical interface**
- **RoHS compliant**

APPLICATIONS

- **100G Ethernet over Duplex MMF**

DESCRIPTIONS

The 40G/100G QSFP28 SWDM4 transceiver modules are designed for use in 100G Ethernet links over duplex multimode fiber. Four channels/lanes in the 850-940nm region @25.78Gbps to transport the Ethernet signal. Digital diagnostics functions are available via an I2C interface, as specified by the QSFP28 MSA.

Module Block Diagram

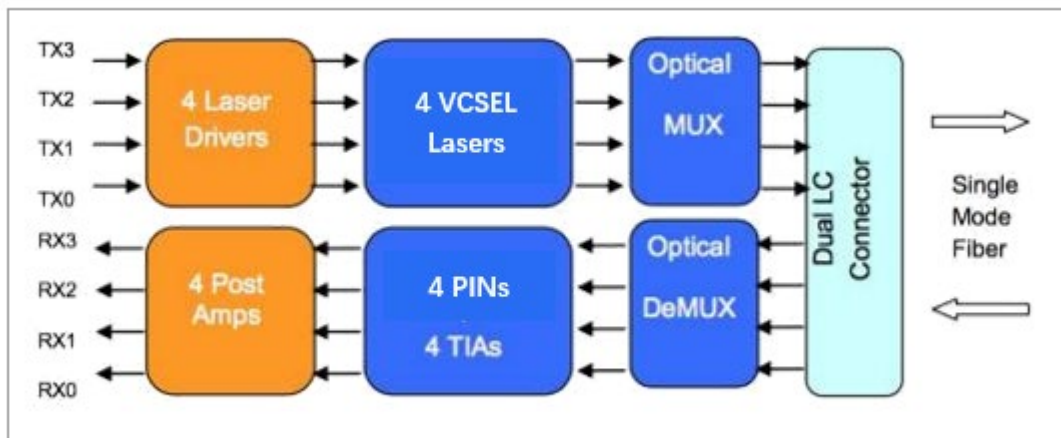

Ordering Information

Part No.	Data Rate(optical)	Laser	Fiber Type	Distance	Optical Interface	Temp	DDMI	Latch Color
EQP89Y-01D-SW4	100G	VCSEL	MMF	150m	LC	0~70°C	Y	White

Absolute Maximum Ratings

Parameter	Symbol	Min.	Max.	Unit
Storage Temp Range	Ts	-40	+85	°C
Supply Voltage	Vcc	-0.5	3.6	V
Relative Humidity	RH	15%	85%	

Recommended Operating Conditions

Parameter	Symbol	Min	Max	Units
Case Temp-Operating	Tcase	0	70	°C
Supply Voltage	Vcc	3.14	3.46	V
Power Consumption	P		3.5	W
Link Distance on OM3 Fiber (100G)			75	M
Link Distance on OM4 Fiber (100G)			100	M
Link Distance on OM5 Fiber (100G)			150	M

Optical and Characteristics@25.78125Gb/s

Transmitter Parameter	Lane	Min	Typical	Max	Unit	Note
Signaling rate, each lane		25.78125±100ppm			Gb/s	
Lane Wavelength Range	Lane0	844		858	nm	
	Lane1	874		888		
	Lane2	904		918		
	Lane3	934		948		
Modulation Format		NRZ				
Difference in launch power between any two lanes				4.5	dBm	
RMS Spectral width				0.59	nm	1
Optical Modulation Amplitude (OMA), each lane		-5.5		3	dBm	2
Average Launch Power per Lane @ TX Off State				-30	dBm	
Launch Power in OMA minus TDEC	Lane0	-7			dBm	
	Lane1	-7				
	Lane2	-7.4				
	Lane3	-7.7				
Transmitter and Dispersion Eye Closure	Lane0			4	dB	3
	Lane1			4		
	Lane2			4.4		
	Lane3			4.8		

Extinction Ratio		2			dB	
Optical Return Loss Tolerance				12	dB	
Encircled Flux		≥86% at 19 um ≤30% at 4.5 um				4
Transmitter eye mask definition {X1, X2, X3, Y1, Y2, Y3}		{0.3,0.38,0.45,0.35,0.41,0.5}				
Hit ratio 1.5x10 ⁻³ hits per sample						

Notes:

1. RMS spectral width is the standard deviation of the spectrum.
2. The normative lowest value of OMA for a compliant transmitter is 'Launch power in OMA minus TDEC, each lane (min)' plus the actual value of 'TDEC', but with a value of at least 'OMA, each lane (min)'.
3. TDEC is calculated from the measured TDECm using the methods in 3.6. TDECm is measured following the method in IEEE 802.3 clause 95.8.5 using a 12.6 GHz bandwidth reference receiver for all lanes.
4. If measured into type A1a.2 or type A1a.3 50 um fiber in accordance with IEC 61280-1-4.

Receiver Parameter	Lane	Min	Typical	Max	Unit	Note
Signaling rate, each lane		25.78125 ± 100ppm			Gb/s	
Lane Wavelength Range	Lane0	844		858	nm	
	Lane1	874		888		
	Lane2	904		918		
	Lane3	934		948		
Modulation Format		NRZ				
Damage Threshold		4.4			dBm	
Average Receive Power, each lane	Lane0	-9.5		3.4	dBm	
	Lane1	-9.4				
	Lane2	-9.4				
	Lane3	-9.4				
Receiver Power, each lane (OMA)				3	dBm	
Receiver Reflectance				-12	dB	
unStressed Receiver Sensitivity(OMA)	Lane0			-8.2	dBm	1
	Lane1			-8.4		
	Lane2			-8.6		
	Lane3			-8.8		
RX_Los_Assert		-30			dBm	
RX_Los_De-ASSERT				-12	dBm	
RX_Los_Hysteresis		0.5			dBm	
1.unstressed sensitivity at BER of 5E-5(pre FEC)						

Digital Diagnostics

Parameters	Unit	Specification
Temperature Monitor	°C	± 3
Voltage Monitor	V	± 5 %
I_bias Monitor	mA	± 10 %
Received Power (Rx) Monitor	dB	± 3.0
Transmit Power (Tx) Monitor	dB	± 3.0

Electrical Characteristics

Transmitter electrical input signal characteristics(TP1)	Min	Typical	Max	Unit
Signaling rate per lane (range)	25.78125 ± 100 ppm			GBd
Differential input return loss	Equation (83E-5)			dB
Differential to common mode input return loss	Equation (83E-6)			dB
Differential termination mismatch			10	%
Module stressed input test	See 83E3.4.1			
Differential pk-pk input voltage tolerance	900			mV
DC common mode voltage	-350		2850	mV
Single ended voltage tolerance range	-0.4		3.3	V
Receiver electrical output signal characteristics(TP4)	Min	Typical	Max	Unit
Signaling rate per lane (range)	25.78125 ± 100 ppm			GBd
AC common-mode output voltage (RMS)			17.5	mV
Differential output voltage			900	mV
Eye width	0.57			UI
Eye height, differential	228			mV
Vertical eye closure			5.5	dB
Differential output return loss	Equation (83E-2)			dB
Common to differential mode conversion return loss	Equation (83E-3)			dB
Differential termination mismatch			10	%
Transition time (20% to 80%)	12			ps

DC common mode voltage	-350		2850	mV
------------------------	------	--	------	----

Pin Diagram

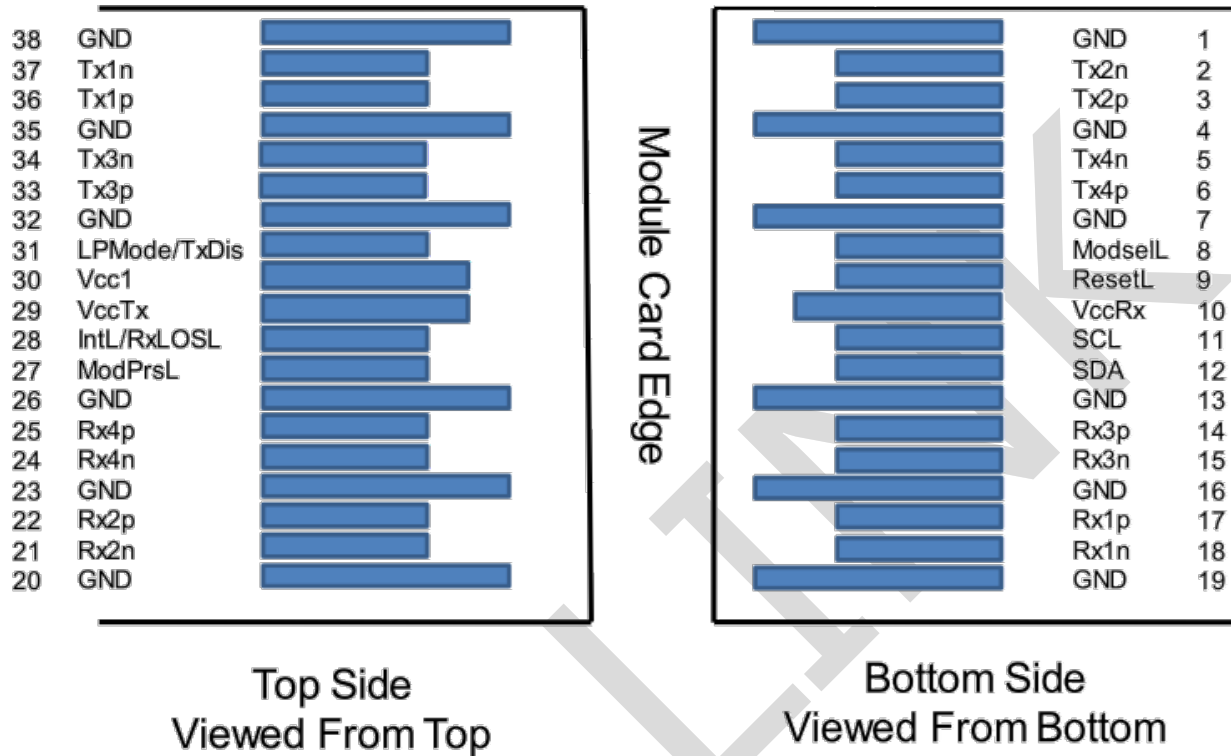

Pin Definitions

PIN	Logic	Symbol	Description	Plug Seq.	Notes
1		GND	Ground	1	1
2	CML-I	Tx2n	Transmitter Inverted Data Input	3	
3	CML-I	Tx2p	Transmitter Non-Inverted Data output	3	
4		GND	Ground	1	1
5	CML-I	Tx4n	Transmitter Inverted Data Input	3	
6	CML-I	Tx4p	Transmitter Non-Inverted Data output	3	
7		GND	Ground	1	1
8	LVTLL-I	ModSelL	Module Select	3	
9	LVTLL-I	ResetL	Module Reset	3	
10		VccRx	+ 3.3V Power Supply Receiver	2	2
11	LVC MOS-I/O	SCL	2-Wire Serial Interface Clock	3	
12	LVC MOS-I/O	SDA	2-Wire Serial Interface Data	3	
13		GND	Ground	1	

14	CML-O	Rx3p	Receiver Non-Inverted Data Output	3	
15	CML-O	Rx3n	Receiver Inverted Data Output	3	
16		GND	Ground	1	1
17	CML-O	Rx1p	Receiver Non-Inverted Data Output	3	
18	CML-O	Rx1n	Receiver Inverted Data Output	3	
19		GND	Ground	1	1
20		GND	Ground	1	1
21	CML-O	Rx2n	Receiver Inverted Data Output	3	
22	CML-O	Rx2p	Receiver Non-Inverted Data Output	3	
23		GND	Ground	1	1
24	CML-O	Rx4n	Receiver Inverted Data Output	3	1
25	CML-O	Rx4p	Receiver Non-Inverted Data Output	3	
26		GND	Ground	1	1
27	LVTTL-O	ModPrsL	Module Present	3	
28	LVTTL-O	IntL/Rx_LOS	Interrupt/Rx_LOS	3	
29		VccTx	+3.3 V Power Supply transmitter	2	2
30		Vcc1	+3.3 V Power Supply	2	2
31	LVTTL-I	LPMODE/TxDIS	Low Power Mode/Tx_Disable	3	
32		GND	Ground	1	1
33	CML-I	Tx3p	Transmitter Non-Inverted Data Input	3	
34	CML-I	Tx3n	Transmitter Inverted Data Output	3	
35		GND	Ground	1	1
36	CML-I	Tx1p	Transmitter Non-Inverted Data Input	3	
37	CML-I	Tx1n	Transmitter Inverted Data Output	3	
38		GND	Ground	1	1

Notes:

1. GND is the symbol for signal and supply (power) common for the QSFP28 module. All are common within the QSFP28 module and all module voltages are referenced to this potential unless otherwise noted. Connect these directly to the host board signal-common ground plane.
2. Vcc Rx, Vcc1 and Vcc Tx are the receiver and transmitter power supplies and shall be applied concurrently. Requirements defined for the host side of the Host Edge Card Connector are listed in MSA. The connector pins are each rated for a maximum current of 1000 mA.

Mechanical Diagram

Unit: mm

Pull tab color: Gray ,Pantone 424U

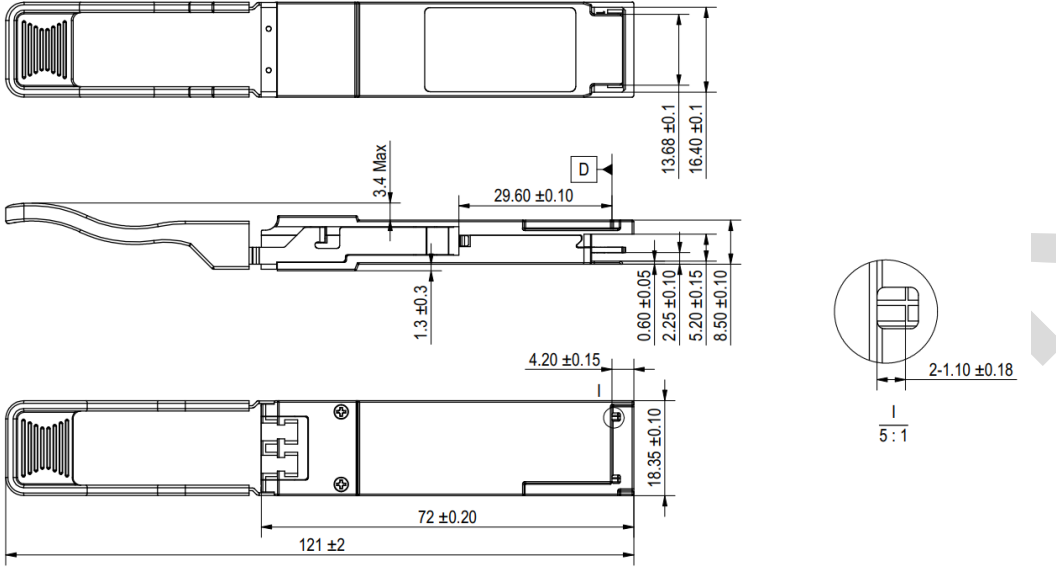

Revision History

Version No.	Date	Description
1.0	October 11,2019	Product upgrades
2.0	July 27, 2024	Format change

Company: ETU-Link Technology Co., LTD
 Production base: Right side of 3rd floor, No. 102 building, Longguan expressway, Dalang street, Longhua District, Shenzhen city, Guangdong Province, China 518109
 R&D base: Floor 4, Building 4, Nanshan Yungu Phase LI, Taoyuan Community, Xili Street, Nanshan District, Shenzhen
 Tel: +86-755 2328 4603

Addresses and phone number also have been listed at www.etulinktechnology.com.
 Please e-mail us at sales@etulinktechnology.com or call us for assistance.