

SFP

ES-T3-RI

10/100BASE-T Copper SFP Transceiver

- Hot-pluggable SFP footprint
- Fully metallic enclosure for low EMI
- Compact RJ-45 connector assembly
- It supports RX_LOS(Loss of Signal) function
- Compatible with IEEE802.3u
- Access to physical layer IC via 2-wire serial bt
- A 10/100BASE-TX/ 100BASE-FX converter
- Operating case temperature range of
-40°C to +85°C (Industrial)



Applications

- This 100Base-TX Copper SFP Transceiver supports the SFP based switch 100Base-FX ports that accept standard 100Base-FX optics SFP.

Description

ETU-Link's ES-T3-RI Copper Small Form Pluggable (SFP) transceiver module is specifically designed for converting 100Base-FX NRZI port interface to 10/100Base-TX interface with RJ45 connector. The transceiver module is compliant with the SFP Multi Source Agreement (MSA) and IEEE802.3u. With the hot plug ability, the module offers a flexible and easy way to be installed into SFP MSA compliant ports at any time without the interruption of the host equipments operating online. The Copper SFP transceivers use an integrated RJ-45 connector with transformer and PHY IC.

Pin Definitions

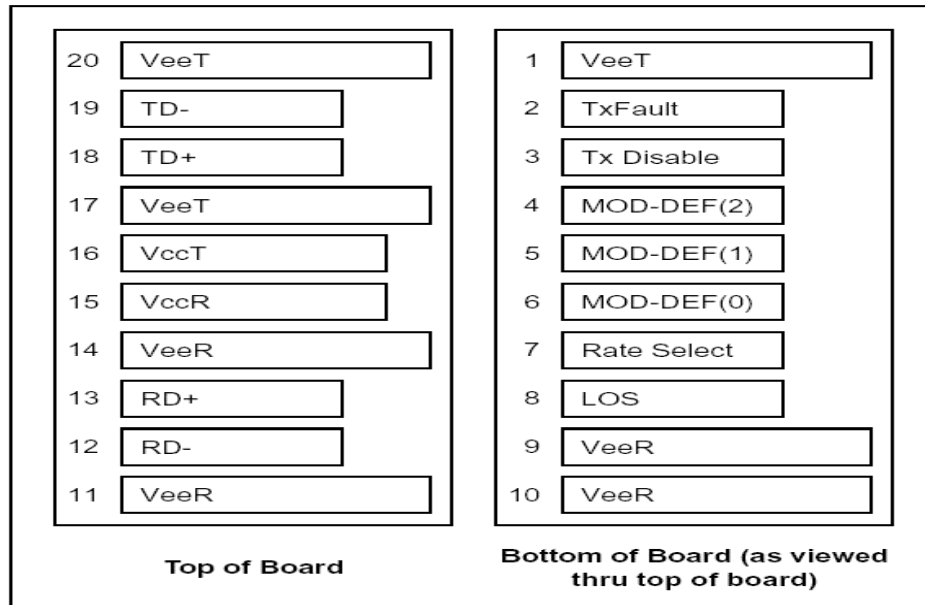

Figure 1. Pin Definitions

Pin Descriptions

Pin	Signal Name	Description	Plug Seq.	Notes
1	V _{EET}	Transmitter Ground	1	
2	TX FAULT	Transmitter Fault Indication	3	Note1
3	TXDISABLE	NC	3	Note2
4	MOD_DEF(2)	SDA Serial Data Signal	3	Note3
5	MOD_DEF(1)	SCL Serial Clock Signal	3	Note3
6	MOD_DEF(0)	TTL Low	3	Note3
7	Rate Select	Not Connected	3	
8	LOS	Loss of Signal	3	Note 4
9	V _{EER}	Receiver ground	1	
10	V _{EER}	Receiver ground	1	
11	V _{EER}	Receiver ground	1	
12	RX-	Inv. Received Data Out	3	Note 5
13	RX+	Received Data Out	3	Note 5
14	V _{EER}	Receiver ground	1	
15	V _{CCR}	Receiver Power Supply	2	
16	V _{CCT}	Transmitter Power Supply	2	
17	V _{EET}	Transmitter Ground	1	
18	TX+	Transmit Data In	3	Note 6
19	TX-	Inv. Transmit Data In	3	Note 6
20	V _{EET}	Transmitter Ground	1	

Notes:

Plug Seq.: Pin engagement sequence during hot plugging.

- 1) TX Fault is not supported and is always connected to ground.
- 2) TX Disable is NC
- 3) Mod-Def 0,1,2. These are the module definition pins. They should be pulled up with a 4.7K to 10K resistor on the host board. The pull-up voltage shall be VccT or VccR
 Mod-Def 0 is grounded by the module to indicate that the module is present
 Mod-Def 1 is the clock line of two wire serial interface for serial ID
 Mod-Def 2 is the data line of two wire serial interface for serial ID
- 4) LOS is an open collector output, which should be pulled up with a 4.7k~10kΩ resistor. Pull up voltage between 2.0V and Vcc+0.3V. Logic 1 indicates loss of signal; Logic 0 indicates normal operation. In the low state, the output will be pulled to less than 0.8V.
- 5) RD-/+ : These are the differential receiver outputs. They are AC-coupled, differential lines with 100 differential termination inside the module.
- 6) TD-/+ : These are the differential transmitter inputs. They are AC-coupled, differential lines with 100 differential termination inside the module.

+3.3V Volt Electrical Power Interface

Parameter	Symbol	Min	Typ	Max	Units	Notes/Conditions
Supply Current	I _s		320	375	mA	1.2W max power over full range of voltage and temperature. See caution note below
Input Voltage	V _{cc}	3.13	3.3	3.47	V	Referenced to GND
Maximum Voltage	V _{max}			4	V	

Low-speed signals, electronic characteristics

Parameter	Symbol	Min	Max	Units	Notes/Conditions
SFP Output LOW	VOL	0	0.5	V	4.7k to 10k pull-up to host_Vcc, measured at host side of connector
SFP Output HIGH	VOH	host_Vcc - 0.5	host_Vcc + 0.3	V	4.7k to 10k pull-up to host_Vcc, measured at host side of connector
SFP Input LOW	VIL	0	0.8	V	4.7k to 10k pull-up to Vcc, measured at SFP side of connector
SFP Input HIGH	VIH	2	Vcc + 0.3	V	4.7k to 10k pull-up to Vcc, measured at SFP side of connector

High-speed electrical interface, transmission line-SFP

Parameter	Symbol	Min	Typ	Max	Units	Notes/Conditions
Line Frequency	fL		125		MHz	5-level encoding, per IEEE 802.3u
Tx Output Impedance	Zout,TX		100		Ohm	Differential, for all Frequencies between 1MHz and 125MHz
Rx Input Impedance	Zin,RX		100		Ohm	Differential, for all Frequencies between 1MHz and 125MHz

High-speed electrical interface, host-SFP

Parameter	Symbol	Min	Typ	Max	Units	Notes/Conditions
Single ended data input swing	Vinsing	250		1200	mV	Single ended
Single ended data output swing	Voutsing	350		800	mV	Single ended
Rise/Fall Time	Tr,Tf		175		psec	20%-80%
Tx Input Impedance	Zin		50		Ohm	Single ended
Rx Output Impedance	Zout		50		Ohm	Single ended

General specifications

General						
Parameter	Symbol	Min	Typ	Max	Units	Notes/Conditions
Data Rate	BR	10		100	Mb/sec	IEEE802.3u
Cable Length	L			100	m	Category 5 UTP. BER <10 ⁻¹²

Notes:

1. Clock tolerance is +/- 50 ppm
2. By default, the ES-T5-RJ45 is a full duplex device in preferred master mode
3. Automatic crossover detection is enabled. External crossover cable is not required

Environmental specifications

Environmental Specifications						
Parameter	Symbol	Min	Typ	Max	Units	Notes/Conditions
Operating Temperature	Top	-40		85	°C	Case temperature
Storage Temperature	Tsto	-40		85	°C	Ambient temperature

Mechanical Specifications

The host-side of the ES-T3-RI conforms to the mechanical specifications outlined in the SFP MSA1. The front portion of the SFP (part extending beyond the face plate of the host) is larger to accommodate the RJ-45 connector.

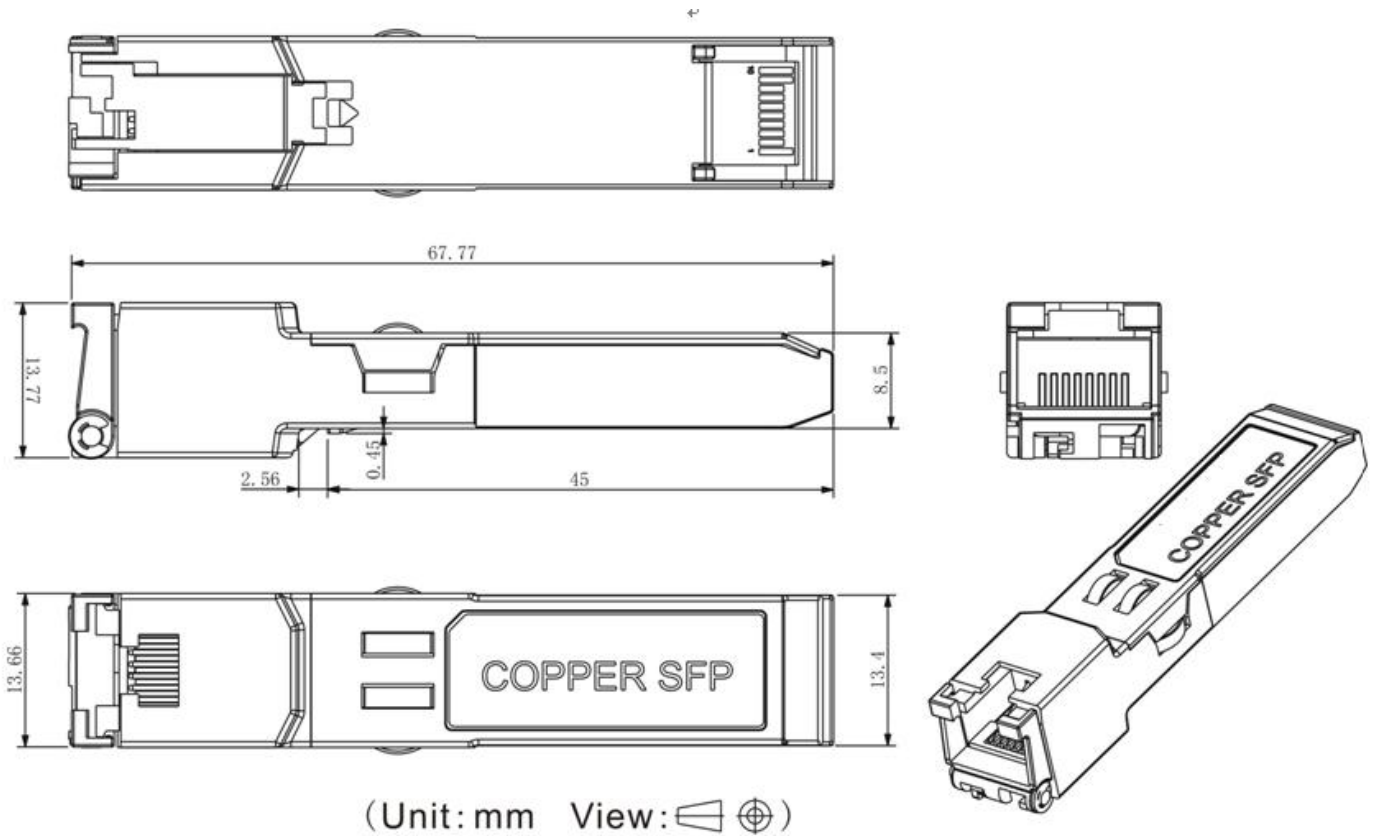

Figure 2. ES-T3-RI mechanical dimensions

Ordering information

Part number	Speed mode	MAC interface	TX Disable function	Link Indicator on RX_LOS Pin	Temp
ES-T1-R	1000Mbps	SERDES	Yes	Yes	0~70°C
ES-T2-R	10/100/1000 Mbps	SGMII	Yes	Yes	0~70°C
ES-T3-R	10/100M	SGMII	Yes	Yes	0~70°C
ES-T3-RI	10/100M	SGMII	Yes	Yes	-40°C~+85°C
ES-T4-R	1000M	SERDES	Yes	Yes	-40°C~+85°C

Regulatory Compliance

Feature	Reference	Performance
Electrostatic discharge (ESD)	IEC/EN 61000-4-2	Compatible with standards
Electromagnetic Interference (EMI)	FCC Part 15 Class B EN 55022 Class B (CISPR 22A)	Compatible with standards
Laser Eye Safety	FDA 21CFR 1040.10, 1040.11 IEC/EN 60825-1, 2	Class 1 laser product
Component Recognition	IEC/EN 60950, UL	Compatible with standards
ROHS	2002/95/EC	Compatible with standards
EMC	EN61000-3	Compatible with standards

Compatibility Test

In order to ensure the product compatibility, our products will be tested on the switch before shipment. Our modules can be compatible with many mainstream brand switches, such as Cisco, Juniper, Extreme, Brocade, IBM, H3C, HP, Huawei, D-Link, Mikrotik, ZTE, TP-Link...

Our test equipment: VOLKTEK MEN-4110, HP 2530-8G, CRS226-24G-25+RM, Catalyst 2960G Series, Catalyst 3850 XS 10G SFP+, Catalyst 3750-E Series, HUAWEI S5700Series, H3C S3100V2 Series, Juniper-EX4200, etc.



Cisco Catalyst 3850



HUAWEI S5700



H3C S3100V2



HP J9264AR



Juniper EX 4200



Alcatel 6850E-U24X



Mikrotik CR5226-24G-25+RM



Cisco Catalyst 2960G



Volktek MEN-4110

Quality Assurance

Continuous introduction of new equipment, produced by strict standards, strict quality inspection, to guarantee the high quality standard of each product.



**Standardized
Production Line**



**Professional
Welding**



Assembling



Aging Testing

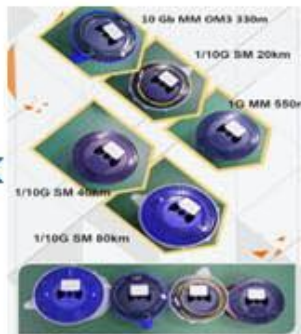

Distance Testing



Cleaning end face



Product Initial Test



Switch Testing



Product Final Test

Packaging

ETU-Link provides two kinds of packaging, 10pcs/Tray and individual package.



Company: ETU-Link Technology Co., LTD

Address: Right side of 3rd floor, No. 102 building, Longguan expressway, Dalang street,
Longhua District, Shenzhen city, Guangdong Province, China 518109

Tel: +86-755 2328 4603

Addresses and phone number also have been listed at www.etulinktechnology.com.

Please e-mail us at sales@etulinktechnology.com or call us for assistance.